

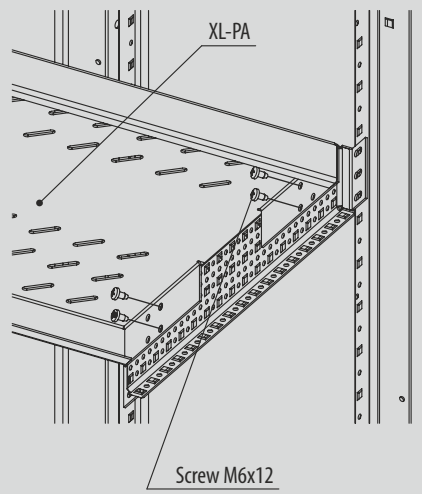

Mounting shelf XL-PA

i Mounting shelf XL-PA is intended for installation of the equipment with a gross weight no more than 150 kg. Fastenings to horizontal rails XL-RH

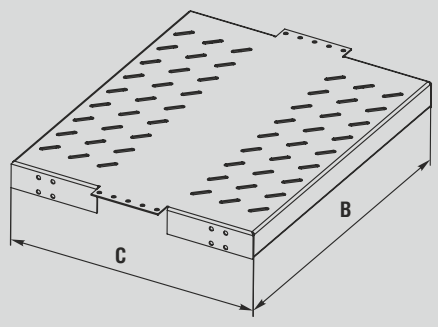
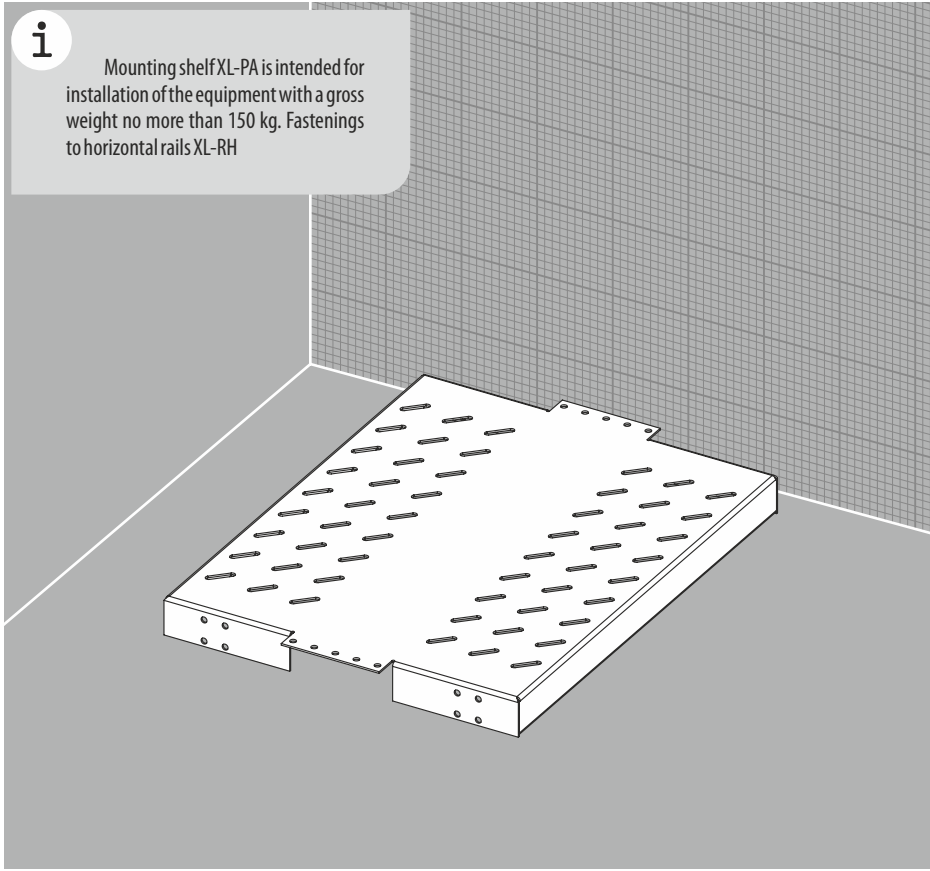

Order No.	Dimensions (enclosure)		Dimensions (mounting shelf)		Weight, kg	Packaging unit, piece
	Width, mm	Depth, mm	B, mm	C, mm		
XL-PA44	400	400	332	220	1,87	1
XL-PA46	400	600	332	420	3,13	1
XL-PA48	400	800	332	620	4,41	1
XL-PA64	600	400	532	220	2,88	1
XL-PA66	600	600	532	420	4,74	1
XL-PA68	600	800	532	620	6,64	1
XL-PA84	800	400	732	220	3,88	1
XL-PA86	800	600	732	420	6,35	1
XL-PA88	800	800	732	620	8,86	1
XL-PA104	1000	400	932	220	4,89	1
XL-PA106	1000	600	932	420	7,96	1
XL-PA108	1000	800	932	620	11,09	1
XL-PA124	1200	400	1132	220	5,90	1
XL-PA126	1200	600	1132	420	9,58	1
XL-PA128	1200	800	1132	620	13,31	1

Technical characteristics

- Material:** sheet steel
- Surface:** zinc-plated
- Supply includes:** shelf + mounting set, package

