

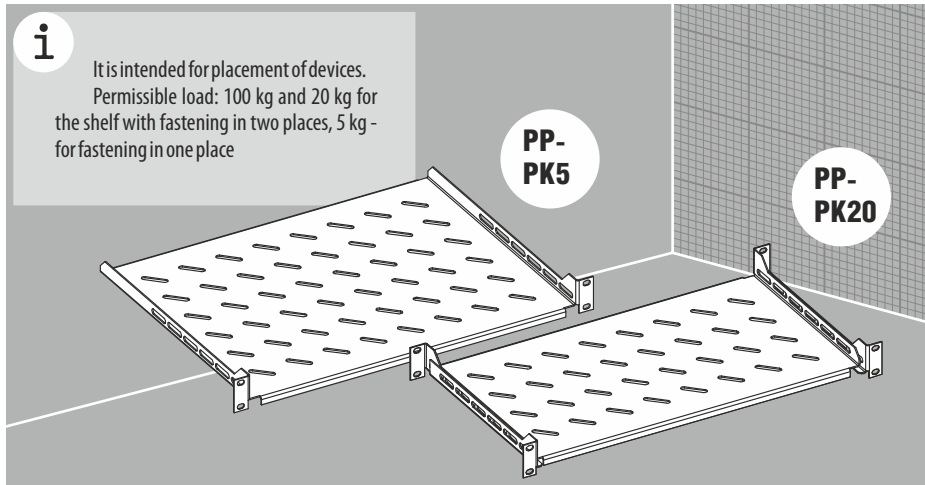

Shelves PP-PK



Technical characteristics

Material: sheet steel
Surface: powder-coated RAL 7035
Supply includes: shelf + mounting set, package

Order No.	Shelfs depth C, mm	Loading, kg	Weight, kg	Packaging unit, piece
PP-PK5-2	250	5	1,49	1
PP-PK5-3	350	5	2,04	1
PP-PK5-4	450	5	2,58	1
PP-PK5-5	550	5	3,10	1
PP-PK20-2	250	20	1,66	1
PP-PK20-3	350	20	2,19	1
PP-PK20-4	450	20	2,73	1
PP-PK100-4	274	100	2,94	1
PP-PK100-6	474	100	4,52	1
PP-PK100-8	674	100	5,99	1
PP-PK100-10	874	100	7,56	1

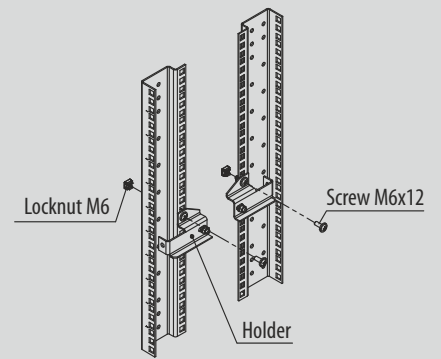
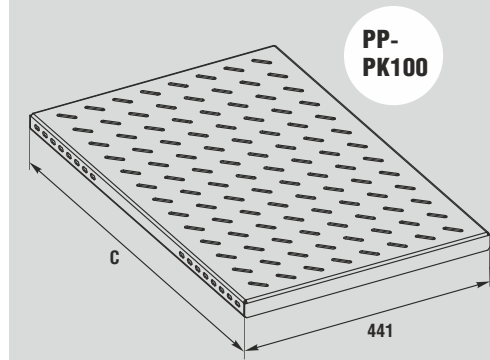

Shelves PV-PK

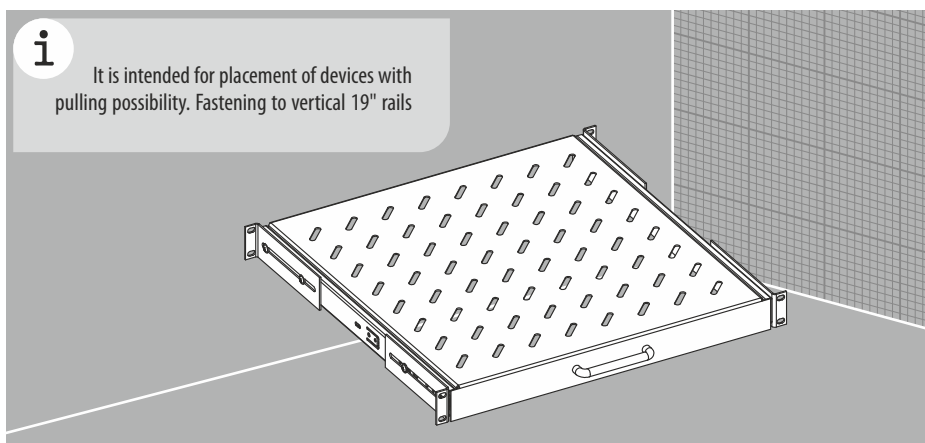

Technical characteristics

Material: sheet steel
Surface: powder-coated RAL 7035
Supply includes: shelf + mounting set, package

Order No.	Shelfs depth C, mm	Loading, kg	Weight, kg	Packaging unit, piece
PV-PK30-4	450	30	5,32	1
PV-PK30-6	650	30	6,77	1

